

2024

Pole Line and Duct System Rate Study City of Grand Rapids, Michigan



Bruce Sweeris

City of Grand Rapids

1/8/2024

Contents

- 1. PREFACE 1
- 2. BACKGROUND 1
- 3. EXECUTIVE SUMMARY 2
- 4. DEFINITIONS..... 3
- 5. POLE LINE AND DUCT SYTEM DESCRIPTION AND RATE METHODOLOGY..... 5
- 6. POLE 5
 - 6.1. POLE CARRYING CHARGE RATE CALCULATION 5
 - 6.2. POLE ATTACHMENT RATE CALCULATION 5
 - 6.2.1. Pole Attachment Rates 5
 - 6.2.2. Pole Attachment Process and Make-Ready Costs 6
 - 6.3. MICRO-CELLS AND SMALL-CELLS ON CITY POLES 6
 - 6.3.1. Annual License Fee..... 6
 - 6.3.2. Pole Attachments..... 6
 - 6.3.3. Pole Use Fee..... 7
 - 6.3.4. Placement Permit..... 7
- 7. DUCT 7
 - 7.1. DUCT CARRYING CHARGE RATE CALCULATION 8
 - 7.2. DUCT USER RATE CALCULATION 8
 - 7.2.1. Duct User Fees 8
 - 7.2.2. Duct Use Permit and Make-Ready Costs 8
 - 7.2.3. Duct Use for Current Agreements 9
- 8. SYSTEM DATA..... 9
- 9. ADMINISTRATION & MAINTENANCE DATA 9
- 10. NET LINEAR COST OF DUCT CALCULATION..... 9
- 11. SUMMARY 9
- 12. USER FEE SCHEDULE 10
- 13. SMALL-CELL WIRELESS FACILITY POLICY 11
- 14. EXHIBIT A – SMALL-CELL PLACEMENT PERMIT APPLICATION 12
- 15. EXHIBIT B – LIST OF SYSTEM USERS 14
- 16. DRAWINGS 15
- 17. INFRASTRUCTURE PHOTOGRAPHS 19

1. PREFACE

The City of Grand Rapids - Energy, Lighting and Communication (ELC) Department owns, operates, and maintains a substantial Street Lighting System, which covers nearly the entire geographical area of the City. This Street Lighting System is comprised of pole lines (utility poles, etc.) and a duct system (conduit, manholes, etc.). These assets allow for power and communication lines to be systematically distributed throughout the City’s network of streets. When this expansive pole line and duct system was constructed, the City had the foresight to design it with excess capacity. Through the years, the City of Grand Rapids has allowed others to occupy City pole lines and ducts with little or no fees, until FY2012. There are numerous entities that utilize the System including City departments, governmental agencies, institutions, private industries, and utilities. It is common practice with other utility companies, such as Consumers Energy and AT&T, to charge their users an annual fee for use of their infrastructure. These fees generally allow the requesting entity to place communications cables in the ducts or on the poles of the host company.

In FY2012 a Rate Study was conducted in order to establish User fees for attachments and duct use. That FY2012 Rate Study was approved by the City Commission, after a public hearing, and rental fees were invoiced. This FY2024 Rate Study is modified from the FY2023 with a 5.1% increase following the Consumers Price Index (CPI). The FY2023 Rate Study follows the same format as the FY2012 Rate Study.

2. BACKGROUND

In July, 2011, the Grand Rapids City Commission adopted Ordinance No. 2011-29, amending the Code of the City of Grand Rapids to create the “Pole Line and Duct System” utility. Section 2.405 of that ordinance requires that users of the System pay user charges to be annually established by City Commission resolutions, which are to be based on recommendations of the City’s Chief Financial Officer, City Manager, and City Attorney. That recommendation is to be based on a study prepared by the System staff in coordination with the City’s Chief Financial Officer and City manager. Subsection 2.405(a) of that ordinance provides:

- (a) The Users of the System shall pay User charges established as set forth below. User charges shall be charged to all System Users within or without the corporate limits of the City. User charges shall reflect the proportionate cost of constructing, installing, operating, repairing, maintaining, replacing, and improving the System. It is desirable that User rates, fees and charges provide sufficient revenues to cover the costs relating to the System including, but not limited to: (i) debt service on any debt of the System, (ii) costs of acquiring, constructing, installing, operating, maintaining, repairing, replacing, extending or enlarging, the System or any portion thereof, (iii) depreciation of any portion or all of the System; (iv) a reasonable rate of return on the System’s investment; (v) debt service or operational coverage that is required under the terms of any System debt, is required by other applicable law, or as is reasonable practice for such systems,

and (vi) all costs relating to billing and collecting any User charges. The User charges shall include fees for application to Use the System, inspection and verification fees for ensuring compliance with System standards, and the pass-through of “make ready costs” as explained in subsection 2-404(a)(6). However, User charges may be established with consideration to the rates, fees and charges of other providers of poles, pole lines, and duct facilities and with consideration to any regulations that, while not applicable to the system, are applicable to other poles, pole lines, and duct facilities. (Emphasis added)

This rate study examines the System’s costs as required by subsection 2.405(a). However, it also reports the rates imposed by other providers of pole lines and ducts. This is key, for three reasons. First, it serves as a reasonable comparison and operates as a “check” of sorts on the reasonableness of the City’s rate. Second, if the City were to impose rates higher than competing rates, then current City customers may choose other providers of those services. At the very least it could dissuade others from using the system. Third, and most importantly, during the consideration of the ordinance representations were made that, at least initially, the City’s rates would not exceed those of other similar providers. This was important to current City customers and, perhaps, also to the City Commission which sought to avoid being under the “market” and thereby unfairly competing, while also not taking advantage of current customers with rates over the “market.”

3. EXECUTIVE SUMMARY

In July of 2011, the Grand Rapids City Commission adopted the “Pole Line and Duct System” utility ordinance to better regulate the excess capacity on its pole line and duct system. The City recognized that it had allowed system users to occupy these facilities with little or no fees, which was inconsistent with the standard operations of other similar utility providers. This System has value to Users because it allows them access throughout the City without digging in the roadways for their own infrastructure, or obtaining private utility easements. Where the duct system is not accessible, the City’s pole line system is available for pole attachments by System Users. System Users, as described in this report, include institutions, governmental agencies, communication companies, utilities, and others. Attached is a known list of System Users located in EXHIBIT A – LIST OF SYSTEM USERS.

This study considered the City’s costs of construction, depreciation, maintenance, administration, and return on investment in determining proposed User fees. The fees were developed based on the guidelines prepared by the Federal Communication Commission (FCC) and the Michigan Public Service Commission (MPSC). These guidelines were used to help establish a reasonable “market” rate as they govern many other providers of similar services in Michigan. As a result, the proposed User fees for the City have been determined, for the most part, to be in line with user fees charged by similar utilities in Michigan.

This study recommends the adoption of the following User fees for the City FY2025:

Pole Line &	Description	Rate	Unit
-------------	-------------	------	------

Duct System	Pole Attachment	\$3.93	Per pole
	Full 4" Duct	\$7.17	Per foot
	1.25" Duct	\$2.06	Per foot
	1" Duct	\$1.38	Per foot
	14mm Duct	\$0.68	Per foot
	10mm Duct	\$0.40	Per foot
Micro-Cells	Pole Type		
	Fiberglass	\$1,204.32	Per Pole
	Ornamental	\$1,728.42	Per Pole
	Square Tapered Steel	\$666.47	Per Pole
	Wood	\$264.05	Per Pole

4. DEFINITIONS

The following definitions shall apply to terms used in this Rate Study. Other terms shall be as defined in the Ordinance.

Carrying Charge: an accounting tool which provides a method of allocating the annual cost of operating a system based upon a percentage of the total infrastructure investment.

Duct: a conduit owned by the City placed under or above the surface of the ground for the purpose of providing space for the placement of power or communications cables or wires. This term is synonymous with Conduit.

Duct Bank: an underground group of conduits arranged in a defined array or pattern, and encased in concrete. Refer to drawings D1 and D2, and photographs P3 through P8.

Duct Riser: a transition system used to provide aerial cable access to the underground ducts. Refer to photograph P11.

Handhole: a shallow access hole large enough for a hand to be inserted for maintenance, repair, and access to the ducts and its contents.

Innerduct: a small (1" to 1¼" in diameter) plastic conduit that is installed in a duct (in groups of 4, 5, or 6) for the purpose of housing multiple cables in one duct. Refer to drawing D1 and photographs P7 and P8.

Make-ready: the cost associated with preparing a pole for a requesting party to be able to make an attachment to a pole. These costs often include correcting potential safety violations in order to maintain compliance with the National Electrical Safety Code (NESC), or relocating other attachments to make room for the new attachment. These costs also apply to placing innerduct in the conduit system for communications to use.

Manhole: an underground concrete chamber built in-place or delivered to the site for the purpose of providing regular access to the ducts. Refer to photographs P7 through P10.

Microduct: a small conduit that is installed in innerduct to further subdivide the duct for the purpose of housing multiple communications cables in one innerduct.

Ordinance: the City of Grand Rapids Ordinance #2011-29 adopted in 2011 to establish the System.

Pole: a City owned utility or street lighting pole.

Pole Attachment: a physical attachment of a cable or device to a wooden City pole. The attachment shall meet the space and elevation requirements of the City, and of the National Electrical Safety Code. Refer to photograph P2.

Pole Attachment Rate: the annual User fee per pole attachment as approved by the City Commission.

Pole Line: two or more poles in a row or otherwise in proximity to one another such that power or communications cables or wires could be strung from one of the poles to one or more other poles.

Rate: the rate applicable for a particular Use of the System.

Revenue Bond Act: the 1933 PA 94, as amended, MCL 141.101 *et seq.*

System: the Grand Rapids Pole Line and Duct System consisting of all poles, pole attachments, ducts, conduits, works, instrumentalities, copper communications cable innerducts, lines, fiber cable, traffic signals, electric power lines and equipment, contract rights, and properties now or hereafter existing, used or useful in connection with such facilities and equipment.

Use: the use of pole lines, ducts, conduits, equipment or other parts of the System by attaching or installing wire, fiber cable, channels, antennas or other lines or equipment on or within such parts of the System and includes even such wire, fiber channels, antennas or other lines or equipment that is not operated until such time as it has been removed or is permitted by the City to stay in place even though it is not operated.

User charge: a fee or charge payable by a User for Use of any part of the System or for costs related to that Use.

User: the person or company who owns the wires, fiber, antennas, or other lines or equipment placed on or within any portion of the System or a person or company other, than the owner of the premises who, according to the provisions of the Ordinance, has the responsibility to pay rates, fees and charges for the Use of any portion of the System.

5. POLE LINE AND DUCT SYTEM DESCRIPTION AND RATE METHODOLOGY

The City of Grand Rapids owns, operates, and maintains a substantial Street Lighting System. The City's poles, wires, and duct system cover nearly the entire geographical area of the City. By nature of its planned construction, this pole line and duct system has excess capacity which has been utilized by others including City departments, governmental agencies, institutions, private industries, and utilities.

Traditionally, other utilities, such as Consumers Energy and AT&T, provide these services and have charged a fee for use of their infrastructure. These fees generally allow the requesting company or entity to place communications cables in the ducts, or on the poles of the host company.

This FY2024 rate study will incorporate the City costs associated with the Pole Line and Duct System from the FY2023 rate study and then increase 5.1% based on the CPI. The Pole Line and Duct System usage will be compiled at the end of FY2024 and will be used along with the rates from this study to invoice the Users of the system for their FY2025 usage. The rates from this study will be prorated for partial year installations that are permitted during FY2025.

6. POLE

6.1. POLE CARRYING CHARGE RATE CALCULATION

The carrying charges include the City Pole administrative, maintenance, depreciation expenses, return on investment, and taxes. See the FY2023 rate study for the calculation.

6.2. POLE ATTACHMENT RATE CALCULATION

6.2.1. Pole Attachment Rates

The guideline used for the basis of establishing the annual rates for parties to attach to the Energy, Lighting, and Communications poles was established by the Federal Communication Commission (FCC) and Governed by Section 224 of the Communications Act of 1934, 47 U.S.C. §224. Section 224 was amended by the Telecommunications Act of 1996 and by several modifications by the FCC since 1996. It is further noted that the State of Michigan has certified to the FCC that it regulates pole attachments in Michigan, which is handled by the Michigan Public Service Commission (MPSC). Though the MPSC is vested with complete power and jurisdiction to regulate all public utilities in the state, this power does not extend to municipally owned utilities. Thus, the FCC guideline will be used as the basis for preparing the rate calculations and the MSPC rates will be used as the market rate comparison.

As a guideline, the preparation of a rate schedule, using the formulas prepared by the FCC, provides the base line for the initial User fees established by the System. Further comparing this

calculated rate with other local utility rates allows adjustment to establish a just and reasonable User fee for the pole attachments.

The maximum calculated rate from the FY2023 rate study was \$18.84 per attachment per year. The current rate approved by the Michigan Public Service Commission for AT&T is \$1.85 per year, and for Consumers Energy is \$3.74 per year.

It is recommended in this rate study that the City adds a 5.1% increase to User fee that was in effect for FY2023 in the amount of \$3.74 per pole attachment per year.

Proposed FY2025 Pole attachment User fee = \$3.93 per pole attachment per year

6.2.2. Pole Attachment Process and Make-Ready Costs

A pole attachment proposal process that is similar to the practice that is currently in use by Consumers Energy will be referenced in the Utility permit application. This process will require applications for new attachments to City poles to complete an application, and as part of that application, pay an engineering review processing fee in the amount of \$59.91 per pole. (A copy of the pole application is attached to this study.) The purpose of this fee is the reimbursement of engineering costs associated with verifying the space and capability of the pole attachment within the capacity for that particular pole, without causing code violation or over taxing the pole. (This fee is based on historical engineering costs for performing this work.) These costs will be better tracked so that, in future years, they are more reflective of actual costs. This rate study recommends maintaining the \$59.91 per pole engineering review processing fee for FY2024.

As part of the engineering review process, any cost to prepare a pole for the requesting user, also known as make-ready costs, by the City will be defined and a request for payment of those fees will be required prior to issuance of a permit to attach.

6.3. MICRO-CELLS AND SMALL-CELLS ON CITY POLES

In accordance with a Non-Exclusive Micro-Cell License Contract with the City of Grand Rapids, the City shall assess the Licensee: an annual license fee, annual pole use fees, and placement permit fees.

6.3.1. Annual License Fee

The annual license fee is specified as part of the Non-Exclusive Micro-Cell License Contract. Licensee shall refer to their contract to find the Annual License fees.

6.3.2. Pole Attachments

As defined in the Rate Study subsection 8.1 Poles, attachment to City poles is confined to wooden poles, however, Micro-Cell and Small-Cell attachments shall be the sole exception. This exception is for the benefit of the City in meeting the ever-demanding requests for

broadband deployment throughout the City. Pole attachments defined under the Non-Exclusive Micro-Cell License Contract shall consider all City Poles for antennae and related equipment installation, but will not cover cable or wire spans between poles.

6.3.3. Pole Use Fee

The licensee requesting attachment to City Poles shall pay fees for the use of the pole in accordance with the License Contract and the annual fee is calculated based on the pole type used for each installation. The method for calculating the rental fees is adding a 5.1% increase from the FY2023 rate:

Pole Type	(FY2023)	x	(increase)	=	Annual Rate
Fiberglass	(\$1,145.88)	x	(5.1%)	=	(\$1,204.32)
Ornamental	(\$1,644.55)	x	(5.1%)	=	(\$1,728.42)
Square Tapered Steel	(\$634.13)	x	(5.1%)	=	(\$666.47)
Wood	(\$251.24)	x	(5.1%)	=	(\$264.05)

Some sites may require having enhanced service provided by the City. These sites will be identified in the Placement Permit process. If a site requires enhanced service, there will be an additional \$321.60 fee added to the annual use fee of the site.

6.3.4. Placement Permit

Defined in the Placement Permit provided under the provisions of the Non-Exclusive Micro-Cell License Contract, the details of the antennae and related equipment shall be reviewed by the City of Grand Rapids Energy, Lighting and Communications Department for compliance with City Code and standards. A one-time fee for the review process will be assessed in the amount of \$155 per pole along with the \$59.91 per pole engineering review processing fee. This fee covers the costs associated with the engineering review of the proposed installation. As part of the engineering review process, any cost to prepare a pole for the requesting user, also known as make-ready costs, by the City will be defined and a request for payment of those fees will be required prior to issuance of a permit to attach.

7. DUCT

The City duct system mainly consist of 4” duct. There are three typical innerduct configurations that are installed in a 4” duct to maximize the conduits capacity. The first configuration is placing six (6) one inch innerducts in the 4” duct. This would therefore provide for a Capacity Percentage of 16.7% for a single one inch cable installation. The second configuration is placing four (4) one and a quarter inch innerducts in the 4” duct. This would therefore provide for a Capacity Percentage of 25.0% for a single one and a quarter inch cable installation. The third configuration is placing a one and a quarter inch innerduct, a four cell fourteen-millimeter microduct, and a seven cell ten-millimeter microduct. This would therefore provide for a Capacity Percentage of 8.3% for a single fourteen millimeter cable installation and a Capacity Percentage of 4.8% for a single ten millimeter cable installation.

7.1. DUCT CARRYING CHARGE RATE CALCULATION

The carrying charges include the City Duct administrative, maintenance, depreciation return on investment, and taxes. See the FY2023 rate study for the calculations.

7.2. DUCT USER RATE CALCULATION

The following sections demonstrate the calculations for determining the User fees for the use of the City Duct System based on the Federal Communications Commission guidelines.

7.2.1. Duct User Fees

It is proposed to use the Federal Communications Commission guidelines as the basis for establishing the annual rate for Users to use space within the City Ducts. The guideline, used for the basis of establishing the annual rates for parties to use the City Ducts, was established by the Federal Communication Commission (FCC) and Governed by Section 224 of the Communications Act of 1934, 47 U.S.C. §224. Section 224 was amended by the Telecommunications Act of 1996 and by several modifications by the FCC since 1996. It is further noted that the State of Michigan has certified to the FCC that they regulate duct user fees in Michigan, which is handled by the Michigan Public Service Commission (MPSC). Though the MPSC is vested with complete power and jurisdiction to regulate all public utilities in the state, this power excludes municipally owned utilities. Thus, the FCC guideline will be used as the basis for preparing the rate calculations.

As a guideline, the preparation of a rate schedule using the formulas prepared by the FCC, provides the base line for the initial User fees established by the System. Further comparing this calculated rate with other local utility rates allows adjustment to establish a just and reasonable User fee for the duct usage.

The method for calculating the rental fees is adding a 5.1% increase from the FY2023 rate:

Size	FY2023 Rate	x	Increase	=	Annual Rate
4"	\$6.82	x	5.1%	=	\$7.17
1"	\$1.31	x	5.1%	=	\$1.38
1.25"	\$1.96	x	5.1%	=	\$2.06
14MM	\$0.65	x	5.1%	=	\$0.68
10MM	\$0.38	x	5.1%	=	\$0.40

*Users who share a 1” or a 1.25” innerduct will be charged at the 14mm duct rate.

7.2.2. Duct Use Permit and Make-Ready Costs

The City's Engineering Department has established fees for utility permits. System Users that have a METRO Act agreement with the City is exempt from paying the Engineering Department fees.

Where make ready is necessary in the duct system to accommodate new cable installations, the City may allow the User to perform make-ready work to work with the Users timeline for installation. The City can provide the material for the User to install. In return, the City will give the User a \$4.20 per foot credit on their annual duct use for installing a complete innerduct complement in a conduit. For projects that require large amounts of make ready, the City may require the User to provide the materials. In this case, the City will provide an additional credit for the materials based on the City's cost for the materials. There may be locations where the City requires a new 4" conduit be built as make-ready. The User will be required to get prior approval from the City on the cost of the make-ready to receive credit for the work.

As part of the permit process, a manhole racking policy will be attached to the permit. This racking policy must be strictly adhered to prevent the User from losing access to use the conduit, and having the City request removal of their facilities for violations. A copy of that manhole racking policy is attached.

7.2.3. Duct Use for Current Agreements

Current agreements in effect at the time of this rate study with current Duct Users will be honored by the City. No new individual agreements will be considered. The Ordinance and Rate Study shall be the preferred method.

8. SYSTEM DATA

See the FY2023 rate study for the system data used in the rate study.

9. ADMINISTRATION & MAINTENANCE DATA

See the FY2023 rate study for the supporting data used in the rate study.

10. NET LINEAR COST OF DUCT CALCULATION

See the FY2023 rate study for the net linear cost of duct calculation used in the rate study.

11. SUMMARY

In the interest of complying with the "Pole Line and Duct System" utility ordinance that was established in July of 2011, this Pole Line and Duct System Rate Study was completed to establish the User fees for use of its assets. Previously the City recognized that it had allowed

system users to occupy these facilities with little or no fees, which was inconsistent with the standard operations of other similar utility providers. This System has value to Users because it allows them access throughout the City without digging in the roadways for their own infrastructure, or obtaining private utility easements. Where the duct system is not accessible, the City’s pole line system is usually available for pole attachments by System Users. System users, as described in this report include institutions, governmental agencies, communication companies, utilities, and others.

This study considered the City’s costs of construction, depreciation, maintenance, administration, and return on investment in determining these proposed User fees. These fees were developed based on the guidelines prepared by the Federal Communication Commission (FCC) and the Michigan Public Service Commission (MPSC). These guidelines were used to help establish a reasonable “market” rate as it governs many other providers of similar services in Michigan. As a result, the proposed User fees for the City have been determined, for the most part, to be in line with user rates charged by similar utilities in Michigan.

The study demonstrated the methodologies for calculating the rates, comparing market rates, and proposing Grand Rapids User fees. As a result of studying the actual applicable costs, while comparing these costs to the overall industry rates, this study recommends the adoption of the following User fees for FY2025:

12. USER FEE SCHEDULE

Pole Line & Duct System	Description	Rate	Unit
	Pole Attachment	\$3.93	Per pole
	Full 4” Duct	\$7.17	Per foot
	1.25” Duct	\$2.06	Per foot
	1” Duct	\$1.38	Per foot
	14mm Duct	\$0.68	Per foot
	10mm Duct	\$0.40	Per foot
Micro-Cells	Pole Type		
	Fiberglass	\$1,204.32	Per Pole
	Ornamental	\$1,728.42	Per Pole
	Square Tapered Steel	\$666.47	Per Pole
	Wood	\$264.05	Per Pole

The Tenant shall pay to the City a user fee for use of the pole attachment and duct system in the amount established in the rate study schedule. If the Tenant fails to pay any user fees within 30 days of the invoice shall be assess 2% and late fee of \$38.00. The fee schedule pursuant to this paragraph is listed above. See Exhibit B for a list of current users.

13. SMALL-CELL WIRELESS FACILITY POLICY

See City ordinance 2019-26 for requirements.

Any tenant requesting attachment to City Poles must meet the following requirements:

- The Nonexclusive Micro-Cell License Contract must be signed before any Placement Permit Application can be submitted.
- Completion of the Placement Permit Application. (See Exhibit A)
- All fees must be paid in full before issuance of permit(s). Outstanding payment will delay the issuance of permit(s).
- Annual pole attachment fees will be pro-rated for the first year.

14. EXHIBIT A – SMALL-CELL PLACEMENT PERMIT APPLICATION



SMALL-CELL PLACEMENT PERMIT APPLICATION INSTRUCTIONS AND PROCEDURES

Licensee Responsibility

1. The licensee is responsible to perform an engineering analysis to determine the placement of the attachment on the pole, in accordance with the provisions of the National Electrical Safety Code (NESC).
2. The licensee, if necessary, must make arrangements with the other attachment owners to move/transfer their facilities in order to meet the NESC requirements.
3. Licensee must mark the small-cell equipment with Licensee's name and provide a toll-free number to call for assistance. The markings shall be large enough to be read from the ground.

Instructions, Required Documents and Fees

- 1. Application and Permit:** Prepare and submit small-cell application and permit proposals prior to performing any work on the City's poles. Please register online by going to <https://inspections.grcity.us/citizenaccess/>.
 - a. Fully complete the Business Information.
 - b. Fully complete the Contractor Information.
- 2. Proposal Plan:**
 - a. Site plan/location
 - b. Define the equipment to be placed, including the size, color, design, identifying tags, equipment manufacturer, equipment specification, etc.
 - c. Describe how the equipment will be affixed to the City Property.
 - d. Describe the manner in which power and any other needed services will be provided to the small-cell equipment, including any wiring, duct or conduit to be used.
 - e. Provide photographs of the proposed equipment.
 - f. Provide drawing(s) detailing the placement of the equipment with details on powering, communication back feed, and means of affixing the equipment and associated components.
 - g. Sign the completed application prior to submittal.
- 3. Approval Process:**
 - a. Energy, Lighting, and Communications Department will review the completed application materials and provide for reviews by other City staff. Incomplete applications will receive notification within 25 calendar days.
 - b. Within 60 business days of receipt of a fully completed application, the Energy, Lighting, and Communications Department will issue a placement permit.

- c. All small-cell equipment shall be placed, installed, operated, maintained, repaired, replaced, and improved only as provided in the placement permit.
 - d. Licensee shall provide as-built drawings to the City promptly after completion of each installation. Any deviation from any requirement in a placement permit shall breach the Contract.
- 4. Fees:**
- a. Pole Inspection Evaluation Fees (\$59.91 per pole)
 - b. Placement Permit Application Fees (\$155 per permit)
 - c. Pole inspection evaluation and placement permit application fees are nonrefundable and nontransferable.
 - d. Annual license fee: see your *Non-Exclusive Micro-Cell License Contract*
 - e. Annual pole attachment fee based on type: see *User Fee Schedule section 12*

15. EXHIBIT B – LIST OF SYSTEM USERS

Current User List		
123.NET		Interurban Transit Partnership
ACD.Net		Kent County
Amway		KLA Labs
Arnie’s		Level 3
AT&T		MDIT
Borgess Health		MDOT
CenturyLink		Meijer
Comcast		Merit
Display Pack		Metro Health
Everstream		Metronet
Flexco		Peninsula Fiber Network
Fiber Tech		RDV
First United Methodist Church		Spectrum Health
FSU/Kendall		Stellar Broadband
GR IT		Telnet
GR Parking		Trinity Health
GR Parks & Recreation		Uniti
GR Traffic Safety		US Signal
GR Water		Van Andel Institute
Grand Bank		Van Eerden
GRCC		Verizon
GRCS		Windstream
GVSU		Zayo

Current Small-Cell License List	
Verizon	Mobilitie
A&T	Zayo

16. DRAWINGS

D1 Duct Bank Detail

D2 Duct Bank Section

D3 Wood Pole with Cobra Head Luminaire

D1 Duct Bank Detail

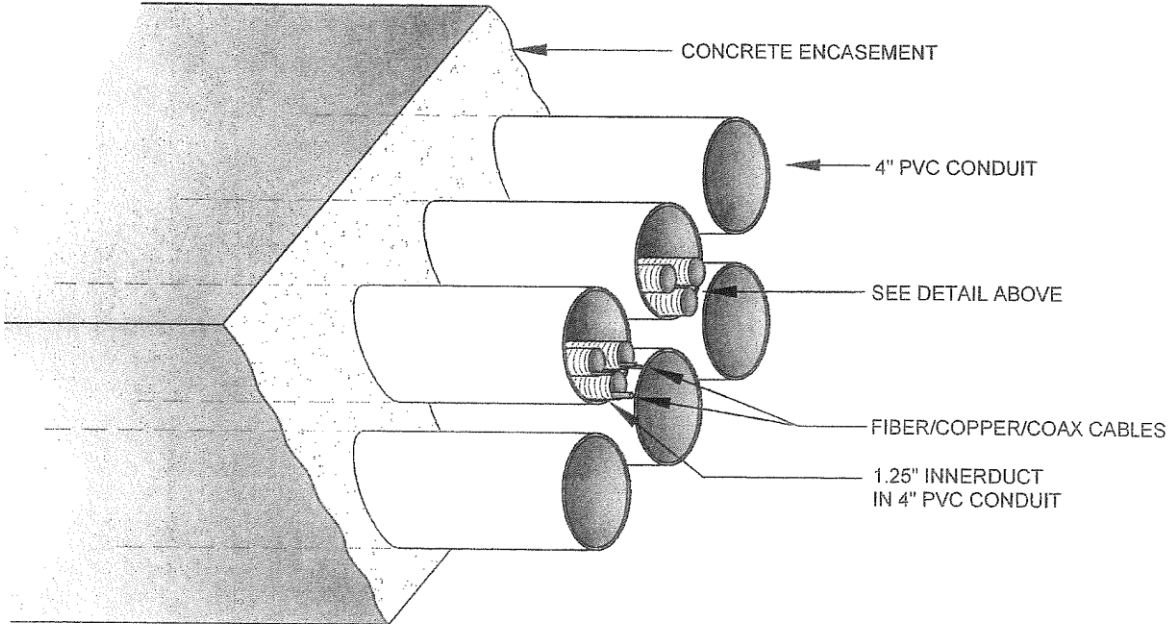
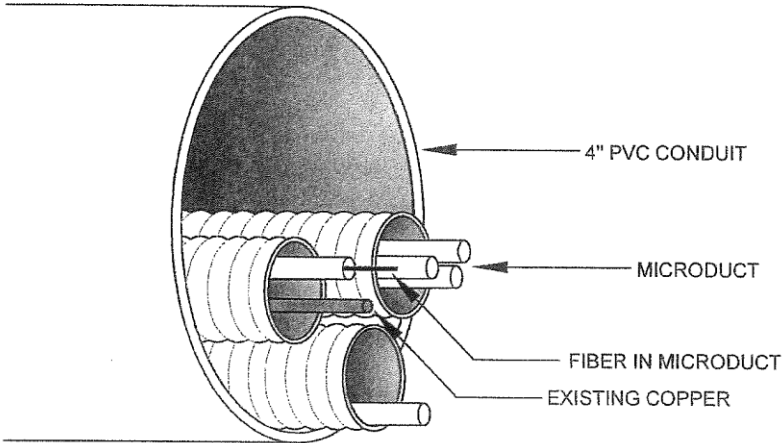

D2 Duct Bank Section

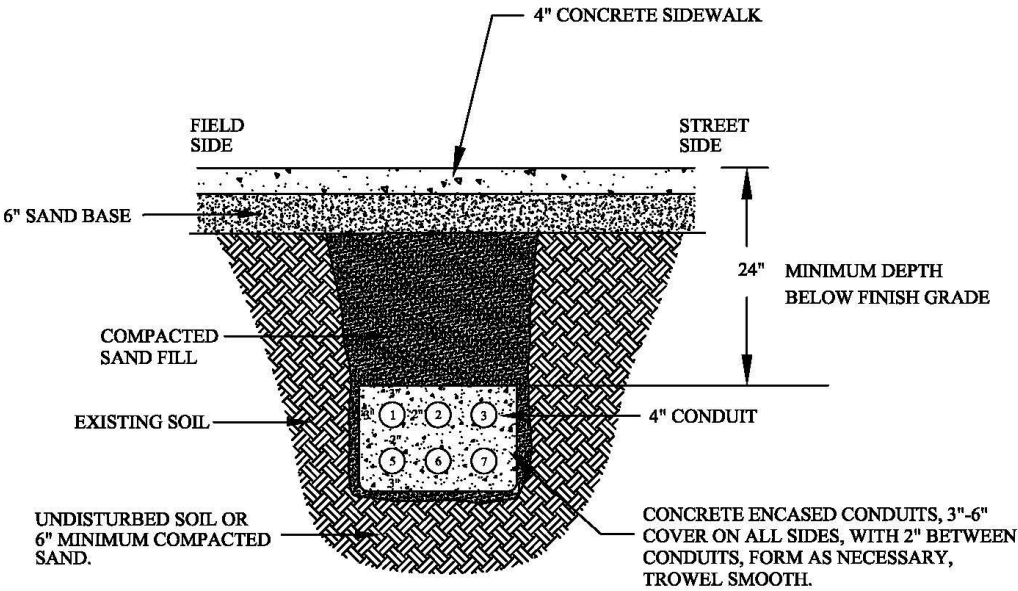

DUCT BANK SECTION
(SHOWN UNDER SIDEWALK)

D3 Wood Pole with Cobra Head Luminaire

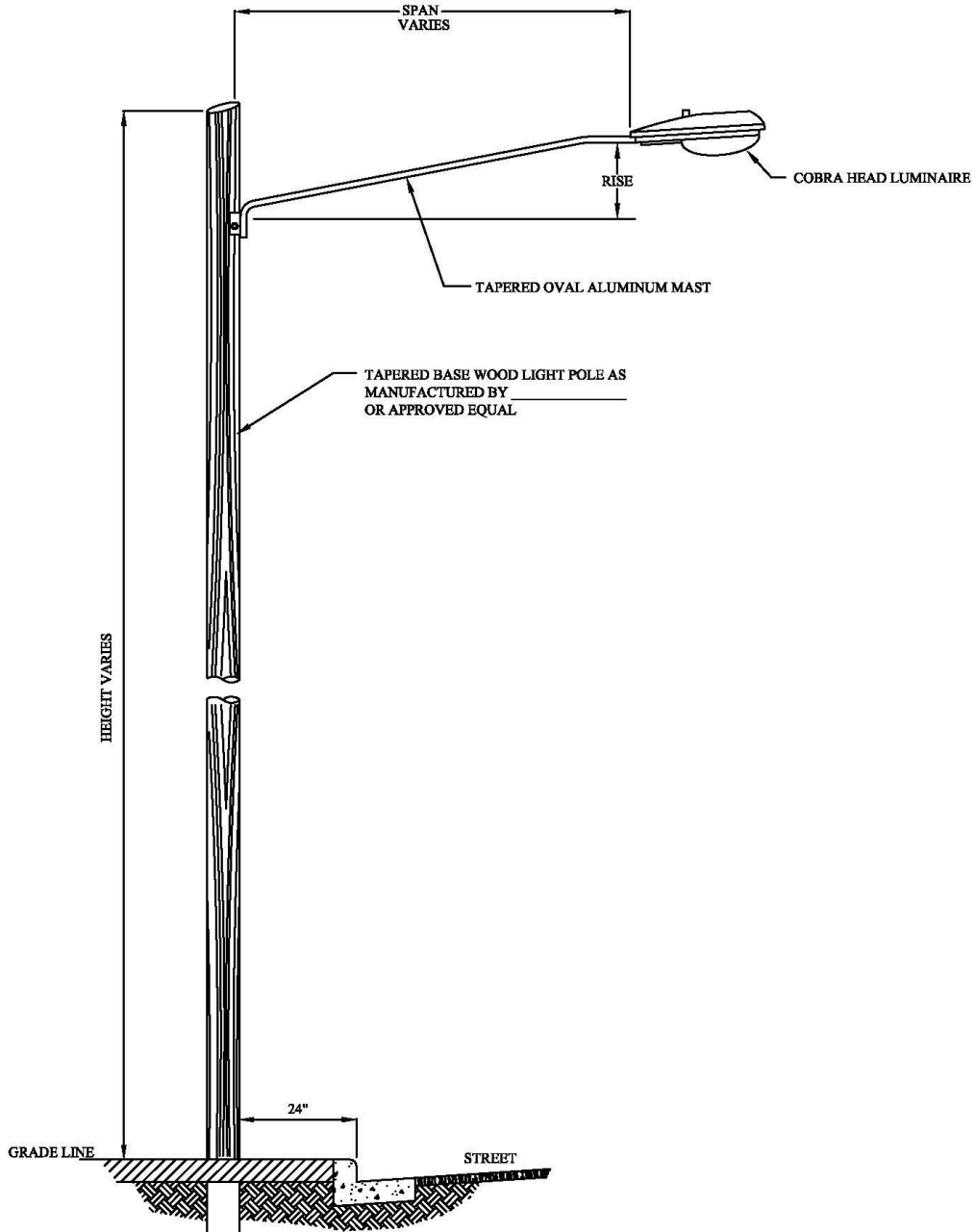

WOOD POLE WITH COBRA HEAD LUMINAIRE
NOT TO SCALE

17. INFRASTRUCTURE PHOTOGRAPHS

- P1 Wood Pole with Cobra Head Luminaire*
- P2 Typical Pole Attachment*
- P3 Duct Installation in Ann Street Bridge*
- P4 Duct Installation in Division Avenue & Buckley Street*
- P5 Duct alongside Storm Sewer under US131*
- P6 Duct Installation in Wealthy Street*
- P7 Manhole Interior 1*
- P8 Manhole Interior 2*
- P9 Manhole Interior Access 1*
- P10 Manhole Interior Access 2*
- P11 Duct Riser*

P1 Wood Pole with Cobra Head Luminaire



P2 Typical Pole Attachment



P3 *Duct Installation in Ann Street Bridge*



P4 *Duct Installation in Division Avenue & Buckley Street*



P5 *Duct alongside Storm Sewer under US131*



P6 *Duct Installation in Wealthy Street*



P7 Manhole Interior 1



P8 Manhole Interior 2

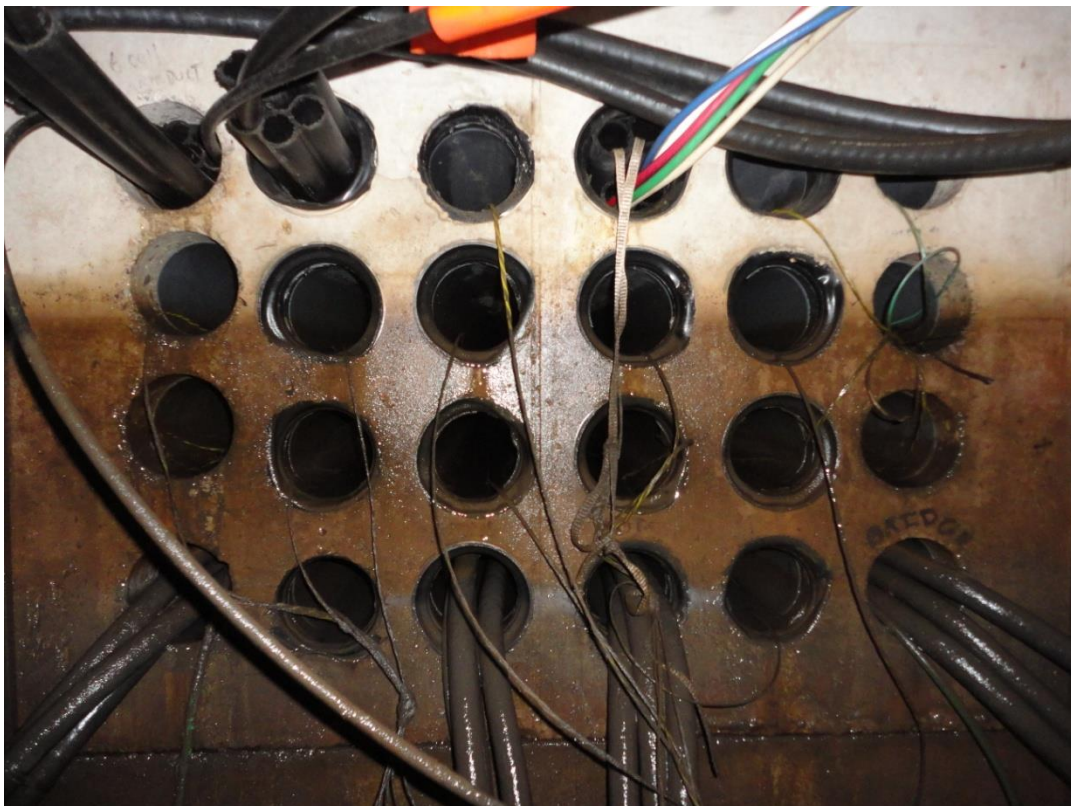

P9 Manhole Interior Access 1



P10 Manhole Interior Access 2



P11 Duct Riser



CITY OF GRAND RAPIDS ENERGY, LIGHTING AND COMMUNICATIONS MANHOLE RACKING POLICY

The placement of cabling through the City conduit/manhole system requires that users adhere to industry standards in the installation of those cables within the system. Inspections by the City will consist of review of the following items for compliance:

- Cable enters the manhole and is directed to the sidewalls for racking on the stanchions within the manhole. Attachment to the stanchions will be made by tie wraps or straps that securely hold the cable in place.
- Cable shall have a label on it that identifies the facility owner, what type of cable it is, and the telephone number of the facility owner.
- Cable shall not cross over or impede the moving of any other cable within the manhole system. Slack coils and splice cases shall be neatly tied back to the walls.
- No cable shall be lying on the floor of the manhole.
- Location of cables in the manholes will be based on function of the facility. Primary cables will be placed in the lowest level of the manhole, with secondary the next level up, and communications cables will be as high as practical in the manhole.
- Cables placed in inner duct shall use the smallest inner duct available for the size of cable that is being placed.

As defined in the permit issued for cable placement within the City Conduit System, as-built drawings reflecting the cable placement shall be sent to the City. A spot review of the installation, as reflected by the as-builts will be conducted. Any violation of the Manhole Racking Policy will be noted and a notice will be sent to the facility owner. The violation shall be corrected within thirty (30) days or the facility owner may be required to remove the cables, at the discretion of the City.